

# VGS™5010,



- Patented COAX® technology.
- The suction cups are specially designed for handling larger parts, such as car body sheets.
- Compatible with any suction cup with G1/2" male fitting. Suction cup ordered separately.
- Available with a two or three-stage COAX® cartridge MIDI. Choose an Si cartridge for extra vacuum flow, a Pi cartridge for high performance at low feed pressure or an Xi cartridge when high flow and deep vacuum is needed.
- The three-stage cartridge will give extra high initial vacuum flow, suitable in high speed applications.
- Easy installation and flexible positioning with several mounting options.

## General

Material	PA, SS, Al, Nitrile (NBR)
Noise level	73 – 83 dBA
Temperature	-10 – 80 °C

## Performance

Feed pressure, max.	0.7 MPa
---------------------	---------

## Vacuum flow

COAX® Cartridge	Feed pressure MPa	Air consumption NI/s	Vacuum flow (NI/s) at different vacuum levels (-kPa)											Max vacuum -kPa
			0	10	20	30	40	50	60	70	80	90		
Pi48-2	0.31	2	2.8	2.5	1.8	1.1	0.65	0.5	0.35	0.25	0.1	—	90	
Pi48-3	0.31	2.05	5.6	2.5	1.8	1.1	0.65	0.5	0.35	0.25	0.1	—	90	
Si32-2	0.6	1.75	3.3	3	2.6	1.7	0.9	0.6	0.5	0.35	—	—	75	
Si32-3	0.6	1.75	6	3.5	2.6	1.7	0.9	0.6	0.5	0.35	—	—	75	
Xi40-2	0.45	1.83	2.8	2.3	1.6	1	0.73	0.58	0.43	0.32	0.18	0.03	95	
Xi40-3	0.45	1.83	5.9	3	2	1.3	0.73	0.58	0.43	0.32	0.18	0.03	95	

## Evacuation time

COAX® Cartridge	Feed pressure MPa	Air consumption NI/s	Evacuation time (s/l) to reach different vacuum levels (-kPa)											Max vacuum -kPa
			10	20	30	40	50	60	70	80	90			
Pi48-2	0.31	2	0.03	0.07	0.13	0.26	0.46	0.7	1	1.6	4	90		
Pi48-3	0.31	2.05	0.02	0.06	0.12	0.25	0.45	0.7	1	1.6	4	90		
Si32-2	0.6	1.75	0.03	0.07	0.1	0.18	0.33	0.53	0.8	—	—	75		
Si32-3	0.6	1.75	0.02	0.05	0.1	0.18	0.33	0.53	0.8	—	—	75		
Xi40-2	0.45	1.83	0.04	0.09	0.17	0.28	0.44	0.63	0.9	1.3	2.3	95		
Xi40-3	0.45	1.83	0.022	0.062	0.12	0.22	0.37	0.57	0.84	1.2	2.2	95		

## Blow flow

COAX® Cartridge	Feed pressure MPa	Air consumption NI/s	Blow flow (NI/s) at different pressure levels (kPa)											Max pressure kPa
			0	10	20	30	40	50	60	70	80			
Si32-2	0.6	1.75	5.05	4.83	4.25	3.61	3.3	2.89	2.65	2.35	1.97	80		
Si32-3	0.6	1.75	7.8	5.4	4.6	3.8	3.3	3.1	2.7	2.3	1.8	80		

## Dimensional drawings

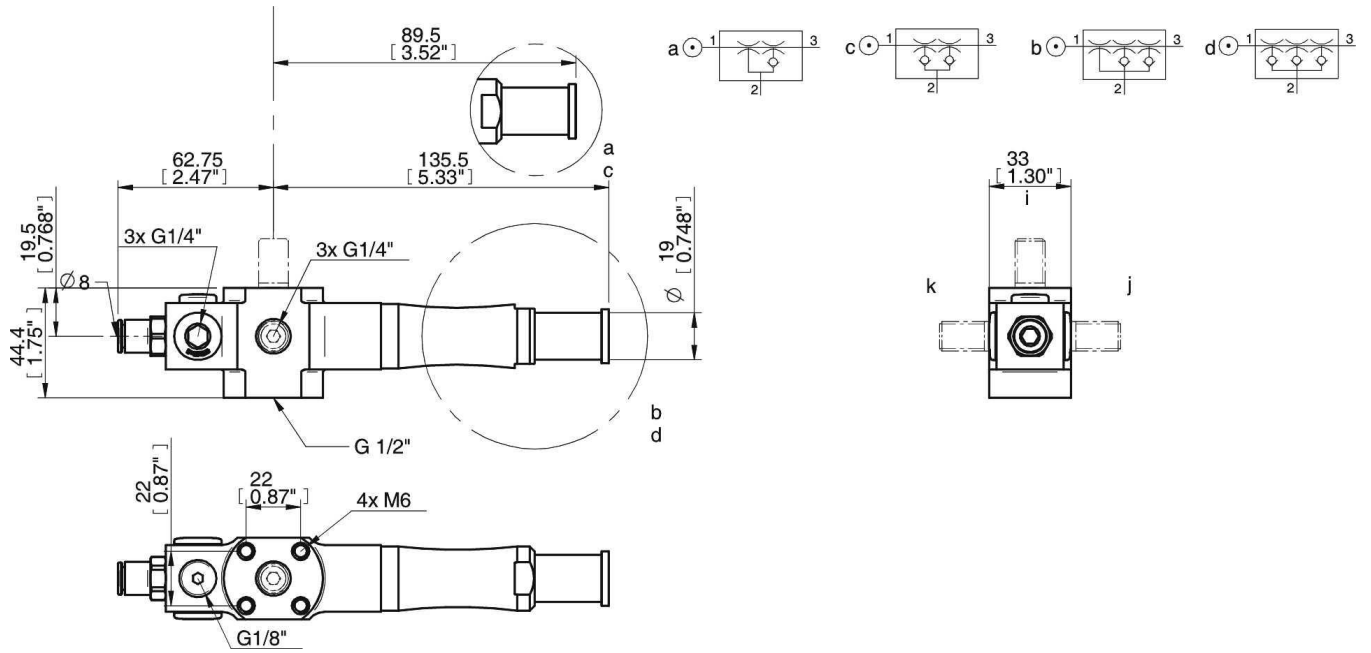

Values specified in the data sheet are tested at:

Room temperature	(20°C [68°F] ± 3°C [5.5°F])
Standard atmosphere	(101.3 [29.9 inHg] ± 1.0 kPa [0.3 inHg])
Relative humidity	0-100%
Compressed air quality	DIN ISO 8573-1 class 4