

Suction cup U20-2P Polyurethane 50, 0119995

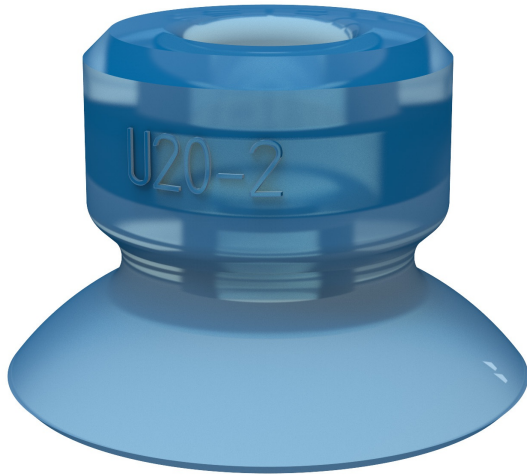

- Long life time suction cup
- Suitable for several book binding applications
- Easy to handle different paper qualities due to the possibilities to order the U20-2P in three different shore
- DURAFLEX® are suction cups manufactured in a specially developed material that features the elasticity of rubber and wear resistance of polyurethane.

General

Curve radius	9 mm
Movement, vertical max.	5 mm
Application	Bag opening/thin paper - slip sheets/film
Material	Polyurethane (PU50)
Suction cup model	U-P
Suction cup shape	Universal
Volume	0.7 cm ³
Weight	1.7 g

Fitting

Fitting size	None
Fitting style	None
Fitting type	None
Fitting option	None

Dimension

Height	14 mm
Outer diameter	20.5 mm

Performance — lifting forces

		
20 -kPa	3 N	1.5 N
60 -kPa	11.5 N	3 N
90 -kPa	15 N	6 N

Material

	Polyurethane (PU50)
Colour	Blue transparent
Hardness	50 °Shore A
Temperature	10 - 50 °C

Material resistance

	Polyurethane (PU50)
Alcohol	N/A
Concentrated acids	+
Ethanol	+
Hydrolysis	+
Methanol	-
Oil	+++
Oxidation	-
Petrol	+
Wear resistance	+++
Weather and ozone	+++

Dimensional drawings

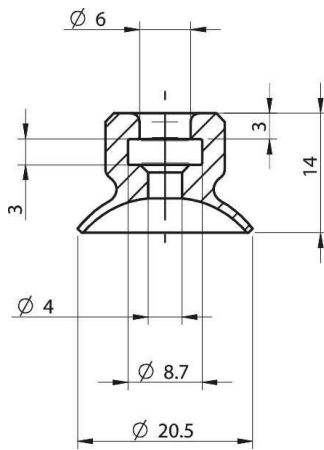

Values specified in the data sheet are tested at:

Room temperature	(20°C [68°F] ± 3°C [5.5°F])
Standard atmosphere	(101.3 [29.9 inHg] ± 1.0 kPa [0.3 inHg])
Relative humidity	0-100%
Compressed air quality	DIN ISO 8573-1 class 4

Accessories

	Item no.
Fitting U20-2P 1/8" male	0205296