

Suction cup F-OB 30x60 Silicone, G1/4" male SS, FCM , 0207048



- The silicone material complies with FDA 21 CFR 177.2600 and EU 1935/2004.
- Transparent color without pigment
- Long lasting high-end silicone material
- Excellent grip on oblong parts such as flow-packs and stick-packs
- Available with threaded and integrated stainless steel fittings.
- Easy to clean with hygienic design. No dust/dirt pockets.

General

Curve radius	11 mm
Movement, vertical max.	10.9 mm
Application	Food contact materials (FDA & EU), non-detectable
Material	ASTM 316L, Silicone (SIL non-detectable FCM)
Suction cup model	F-OB
Suction cup shape	Oval Bellows
Volume	17.5 cm ³
Weight	67.1 g

Fitting

Fitting size	1/4"
Fitting style	Male
Fitting type	G-thread
Fitting option	None

Dimension

Height	49.9 mm
Length	62 mm
Width	32 mm

Performance — lifting forces

		
10 -kPa	8 N	8.1 N
20 -kPa	17.2 N	13.4 N
40 -kPa	31.1 N	27.5 N

Material

	Silicone (SIL non-detectable FCM)
Colour	Transparent
Hardness	40 °Shore A
Temperature	-40 – 200 °C

Material resistance

	Silicone (SIL non-detectable FCM)
Alcohol	++
Concentrated acids	-
Ethanol	N/A
Hydrolysis	+
Methanol	N/A
Oil	-
Oxidation	+++
Petrol	-
Wear resistance	++
Weather and ozone	+++

Dimensional drawings

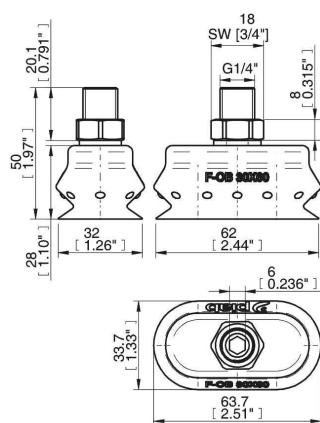

Values specified in the data sheet are tested at:

Room temperature	(20°C [68°F] ± 3°C [5.5°F])
Standard atmosphere	(101.3 [29.9 inHg] ± 1.0 kPa [0.3 inHg])
Relative humidity	0-100%
Compressed air quality	DIN ISO 8573-1 class 4