

Suction cup BL50-3P Polyurethane 30/70, 1/2" NPT male, 0113746



- High-flow fitting allowing high initial vacuum flow needed for plastic bag handling.
- Suitable for level adjustment and uneven surfaces.
- Dual hardness allowing strength and stability in conjunction with softness and flexibility.
- DURAFLEX® material features the elasticity of rubber in combination with the wear resistance of polyurethane.
- The DURAFLEX® material is mark-free.

General

Curve radius	16 mm
Movement, vertical max.	26 mm
Application	Bag handling
Material	Polyurethane (PU30), Polyurethane (PU70)
Suction cup model	BL-3-P
Suction cup shape	Multibellows
Volume	54 cm ³
Weight	24 g

Fitting

Fitting size	1/2"
Fitting style	Male
Fitting type	NPT-thread
Fitting option	None

Dimension

Height	91 mm
Outer diameter	50 mm

Performance — lifting forces

		
20 -kPa	24 N	22 N
60 -kPa	60 N	49 N
90 -kPa	75 N	60 N

Material

	Polyurethane (PU30)	Polyurethane (PU70)
Colour	Yellow	Black
Hardness	30 °Shore A	70 °Shore A
Temperature	10 – 50 °C	10 – 50 °C

Material resistance

	Polyurethane (PU30)	Polyurethane (PU70)
Alcohol	N/A	N/A
Concentrated acids	+	+
Ethanol	+	+
Hydrolysis	+	+
Methanol	-	-
Oil	+++	+++
Oxidation	-	-
Petrol	+	+
Wear resistance	+++	+++
Weather and ozone	+++	+++

Dimensional drawings

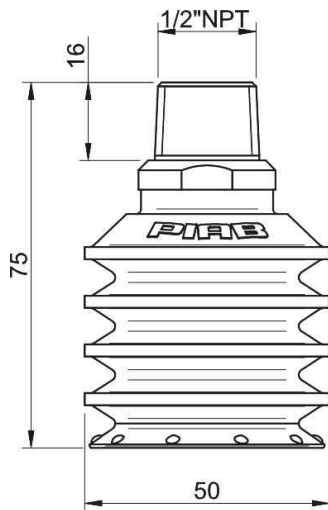

Values specified in the data sheet are tested at:

Room temperature	(20°C [68°F] ± 3°C [5.5°F])
Standard atmosphere	(101.3 [29.9 inHg] ± 1.0 kPa [0.3 inHg])
Relative humidity	0-100%
Compressed air quality	DIN ISO 8573-1 class 4

Spare parts

	Item no.
Fitting 1/2" NPT male, bag	0113140
Suction cup BL50-3P Polyurethane 30/70	0112641

Accessories

	Item no.
Fitting G1/2" male, bag	0113117