

Nidec Brushless DC Servo Motors

BONDY

INDUSTRIAL EQUIPMENT SUPPLIER

For ordering and questions call

(+45) 70 15 14 14

BRUSHLESS DC MOTOR & SPEED CONTROL DRIVERS

FHD Series

DC24V (20, 40W) DC48V (60W)

■Distinguishing Features

- Motors are designed small and high performance
 - We recently released a special magnetic circuit design motor. This motor design is smaller and has a higher performance than conventional FED, FYD series motors.
 - Flange size of this series is 61mm sq. (2.4 in sq.). However flange size of 40W & 60W types are 80mm sq. (3.1 in sq.)
- Compact design Driver
 - "Palm Mini R" Type is the smallest. (20W, 40W only)
 - "Palm Mini PLUS" Type is small. (20W, 40W only)
 - "J - Book" Type is (60W only)
 - High power type is a circuit-board and superconducting type. (20W, 40W)
- Wide Ranged Speed Control (60W only)
 - Wide range (200r/min-2500r/min 60W:65r/min-2500r/min), stepless speed control.
 - Very steady characteristics (Feed back control employed).
- Speed pulse output
 - Speed pulse output can be used for speed monitoring, simplified position control...
 - "Palm Mini R" Type: 42 pulse/revolution
 - "Palm Mini PLUS" Type: 42 pulse/revolution
 - "J - Book" Type: 42 pulse/revolution
 - "High power simple" Type: 7 pulse/revolution output is available for speed monitoring and simplified position control are possible.
- Direction of rotation signal output
 - Direction of rotation can be monitored by this signal.
- Alarming
 - At an over-load condition, the motor stops and an alarm signal is output.

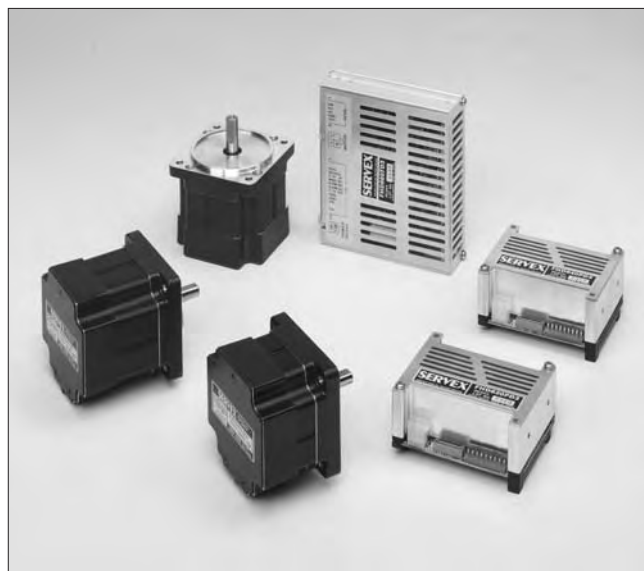

■Model Code

Model on set FHD 6 P 20 PF - D3

①
②
③
④
⑤
⑥

- Series name
- Motor flange dimensions
6 : 61X61mm (2.4X2.4 in.)
- Driver type
P: Palm mini PLUS type
J: J - Book type
- Motor output
20: 20W
40: 40W
60: 60W

- Motor output shaft type
S : Plain shaft
PF: Pinion shaft
PE : Pinion shaft
- Power supply voltage
D3: DC24V
D5: DC48V

Model on motor FH 6 PF 20 H - D3

①
②
③
④
⑤
⑥

- Series name
- Adapting motor flange dimensions
6: 61X61mm (2.4X2.4 in.)
- Motor output shaft type
S: Plain shaft
PF: Pinion shaft
PE: /

- Motor output
20: 20W
40: 40W
- Adapting Driver type
H: High power simple type driver
R: Palm mini R type driver
- Power supply voltage
D3: DC24V

Model on driver FHD 6 20 H D3

①
②
③
④
⑤

- Series name
- Adapting motor flange dimensions
6: 61X61mm (2.4X2.4 in.)
- Motor output
20: 20W
40: 40W

- Driver type
H: High power simple type driver
R: Palm mini R type driver
(Holding torque can be generated)
- Power supply voltage
D3: DC24V

Palm mini PLUS type J-Book type

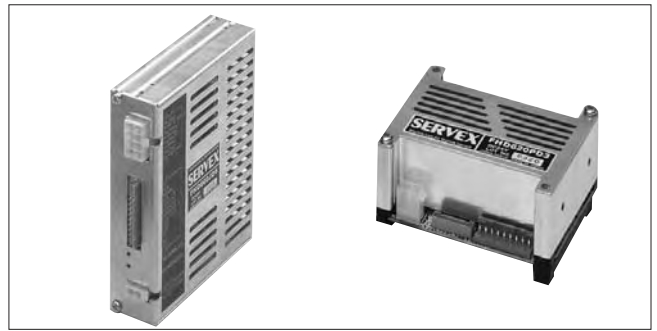

■Specification

Model on set	Plain shaft type		FHD6P20S-D3	FHD6P40S-D3	FHD6J60S-D5			
	Pinion shaft type		FHD6P20PF-D3	FHD6P40PE-D3	FHD6J60PE-D5			
Rated voltage	V (DC)		24	24	48			
Rated output	W		20	40	60			
Speed control range	r/min		200~2500	200~2500	65~2500			
Rated torque	mN · m		98	200	290			
	oz · in		14	28	42			
MAX. instantaneous torque (in 5sec.)	mN · m		150 (2000r/min MAX.)	290 (500r/min MAX.)	440 (1500r/min MAX.)			
	oz · in		21 (2000r/min MAX.)	42 (500r/min MAX.)	62 (1500r/min MAX.)			
Rated speed	r/min		2000	2000	2000			
Speed setting method			①Speed setting by external speed setter (Sold separately: model code Q-R10KB) ②Speed setting by external voltage supply 0~10V					
Speed setting	(r/min)/V		300±5%					
Speed variation	Against load		±1%	0~rated torque at rated voltage and speed				
	Against voltage		±1%	Rated voltage ±10% at rated speed, no load				
	Against temperature		±3%	20±20°C at rated voltage and speed, no load				
Input and output signal	Input		RUN, BRAKE, F/R IN, ALARM RST (Only 60W) H: Open collector L: GND (0~0.8V)					
	Output		ALARM, SPEED OUT (PULSE OUTPUT), F/R OUT Open collector output DC30V MAX. 10mA MAX.					
Speed pulse	Pulse/Revolution		42	42	42			
Current	Rated (Ave.)		1.8 MAX.	3.1 MAX.	2.3 MAX.			
	MAX. (Peak)		9 MAX.	10 MAX.	10 MAX.			
Protection functions			Over load protection When an exceeding torque than rated is applied to motor for more than about 5 sec., Stop motor and outputs "L" from "ALARM" (20W, 40W) or "ALARM OUT" (60W). To release alarm : Palm Mini PLUS type: Disconnect power supply for more than 1min J-Book type: Input "L" to "ALARM RST" for more than 1sec. Do not measure/ judge by this operation whether the motor is overloaded or not.					
Others			Operation temperature: 0~40°C (no condensation) continuous duty. The motor flange surface temp. must be 80°C MAX. (Ambient temperature 40°C without heat sink) Motor dielectric strength: Withstand for 1min. under AC500V 50Hz (Between case and coil) Motor insulation resistance: 10MΩMIN. (20W, 40W) 100MΩMIN. (60W) (Between case and coil by DC500V tester)					
Gear ratio	Speed (r/min)		Applicable MAX. Torque for gearheads					
	at 200r/min	at 2000r/min	6H□EBN		8F□EBN			
			mN · m	oz · in	mN · m	oz · in	mN · m	oz · in
5	40	400	390	56	780	110	1200	170
10	20	200	780	110	1600	220	2400	330
25(25.44)	8	80	1700	250	3600	510	5500	780
50(49.6)	4	40	3500	500	7000	1000	10600	1500

End of production

- □: rotation of gear head output shaft becomes reverse direction of motors.
- In case of 8F□EBN value in () should be used as gear ratio.

Torque Speed/Current (TYP.) Characteristics

FHD6P20S(PF)-D3

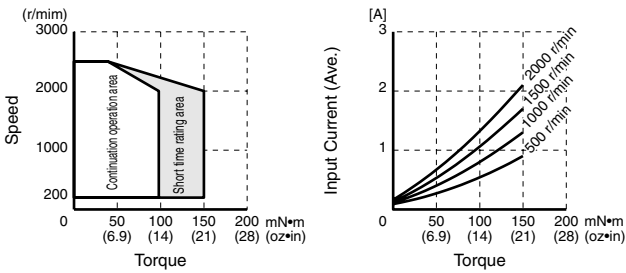

FHD6P40S(PE)-D3

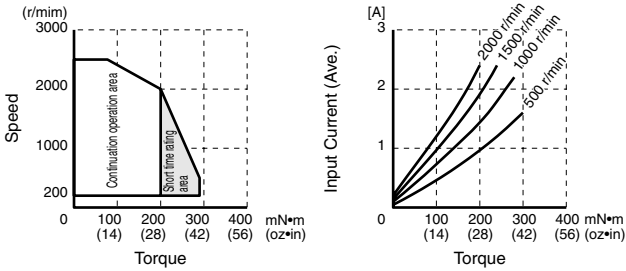

FHD6J60S(PE)-D5 End of production

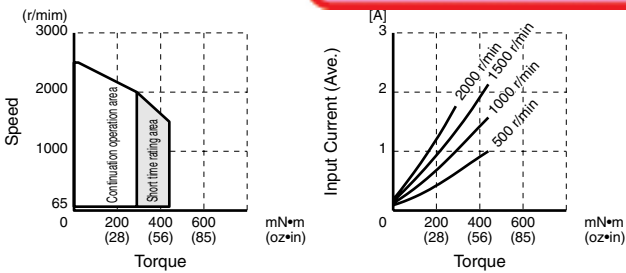

Motor outlines (Plain shaft type)

Unit: mm (inch)

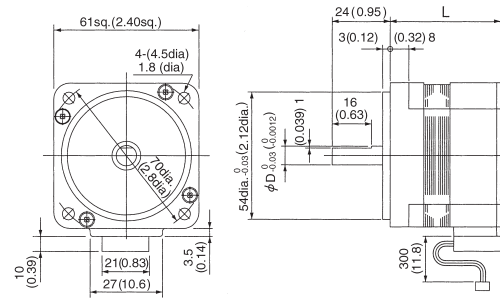

	Model	L	D:dia	Weight	
				Kg	(lb)
①	FHD6P20S-D3	46 (18.1)	8 (0.3150)	0.5	1.1
②	FHD6P40S-D3	60 (2.36)	8 (0.3150)	0.7	1.5
③	FHD6J60S-D5	60 (2.36)	10 (0.3937)	0.7	1.5

Connection guide

	Symbol	20 / 40W		60W		Remark
		① PIN #	Lead wire color	③ PIN #	Lead wire color	
Motor connector	Coil U	1	Brown	3	Brown	
	Coil V	2	Red	4	Red	
	Coil W	3	Orange	8	Orange	
	-	4	-	-	-	
	HW	5	Green	7	Green	Open collector
	HV	6	Blue	6	Blue	Open collector
	HU	7	Purple	5	Purple	Open collector
	GND	8	Gray	1	Gray	
	12V	9	White	2	White	

Motor (Pinion shaft type) + Gear head outlines

FHD6P20PF-D3+6H□EBN

Unit: mm (inch)

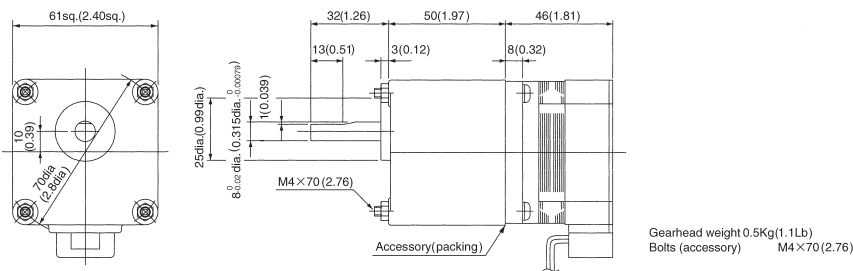

FHD6P40PE-D3+8F□EBN

FHD6J60PE-D5+8F□EBN

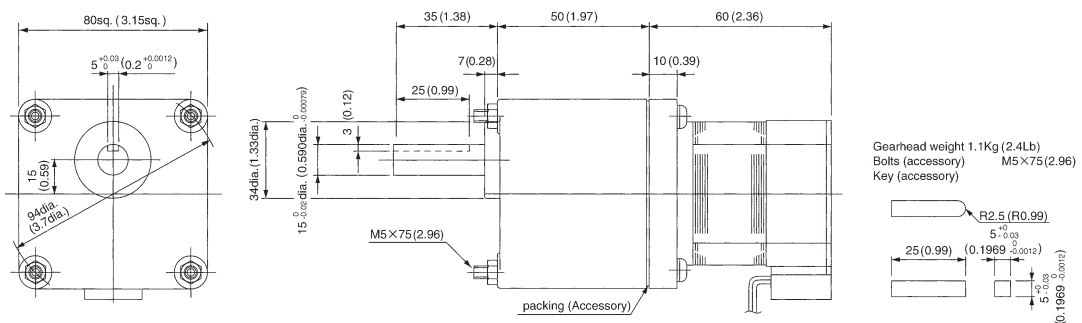

Input & output terminals and wiring diagram

FHD6P20S(PF)-D3

FHD6P40S(PE)-D3

Item	Pin No.	Symbol	Input or Output	Function	Standard • Condition
Power supply	1	VM	Input	Power supply positive for driver	DC24V±10%
	2	P.GND	-	Power supply GND for driver	
I/O	1	SPEED OUT	Output	42 Pulse/Revolution *3	*1 H: Open collector DC30V MAX. L: 0~0.8V 10mA MAX.
	2	F/R OUT	Output	H: CCW L: CW (Viewed from motor output shaft side)	
	3	VR	Output	Power supply positive for external speed setter	0~10V
	4	VS	Input	Speed setting signal positive	
	5	GND	-	Speed setting signal GND	
	6	GND	-	GND for I/O Signal	Same as *1
	7	ALARM OUT	Output	H: Normal operation L: Alarm output	
	8	F/R IN	Input	H: CCW L: CW (Viewed from motor output shaft side)	
	9	BRAKE	Input	H: BRAKE Deactivated L: BRAKE activated	H: Open collector L: 0~0.8V During the operation of "BRAKE", "RUN" signal be "L".
10	RUN	Input	H: Stop L: Start	Same as *2	

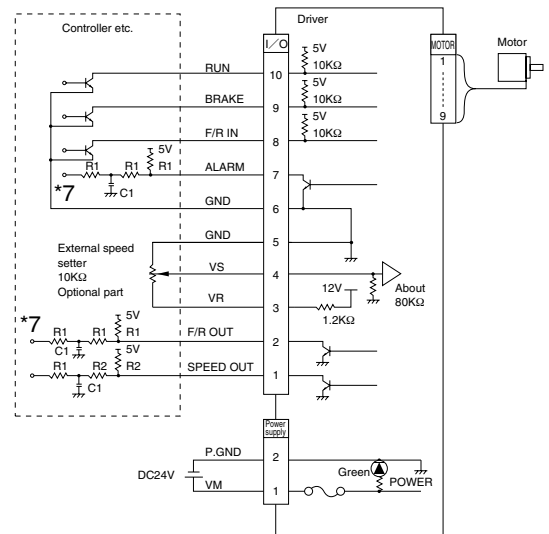

*3 "SPEED OUT" signal is shown below.

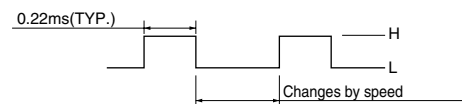

FHD6J60S(PE)-D5

End of production

Item	Pin No.	Symbol	Input or Output	Function	Standard • Condition
Power supply	1	VM	Input	Power supply positive for driver	DC48V±10%
	2	P.GND	-	Power supply GND for driver	
I/O	1	NC	-		*4 H: Open L: 0~0.8V
	2	RUN	Input	H: Stop L: Start	
	3	BRAKE	Input	H: BRAKE Deactivated L: BRAKE activated	
	4	F/R IN	Input	H: CCW L: CW (Viewed from motor output shaft side)	
	5	SPEED OUT	Output	42 [Pulse/Revolution] *6	Same as *5
	6	ALARM RST	Input	H: Normal operation L: Reset	Same as *4
	7	ALARM OUT	Output	H: Normal operation L: Alarm output	*5 H: Open collector DC30V MAX. L: 0~0.8V, 10mA MAX.
	8	F/R OUT	Output	H: CCW L: CW (Viewed from motor output shaft side)	
	9	GND	-	GND for I/O Signal	0~10V
	10	GND	-	Speed Setting Signal GND	
	11	VS	Input	Speed Setting Signal Positive	
	12	NC	-	Not Connected	
	13	VR	Output	Power Supply Positive for External Speed Setter	

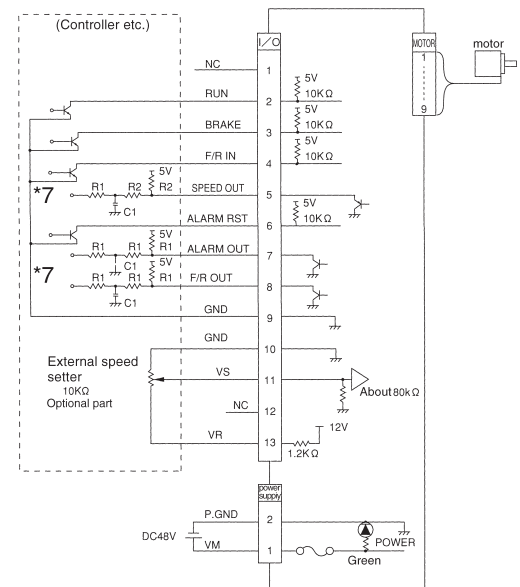

*8

Part name	Recommended value
R1	4.7KΩ
R2	1KΩ
C1	0.01μF

*6 "SPEED OUT" signal is shown below.

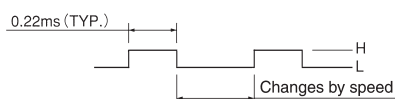

note

- When input signal is H, input signals (RUN, BRAKE, F/R IN, and ALARM RST (60 W Only)) should be input by open collector. If you input 5 V, it will cause the operation to malfunction.
- Noise of output signals ("ALARM" (20W, 40W) "ALARM OUT" (60W)), "F/R OUT", "SPEED OUT") should be removed by a filter as shown in figure above. (*7) Setting of filter constant should be done by confirming the noise level referring to the recommended constant. (*8) The signal delays if the resistance and/or capacitor is large. However, this is a good way to control the noise. Especially for speed out, setting should be done with attention to filter constant because pulse width is narrow.

Speed setting

Fig.1 Speed setting by external speed setter

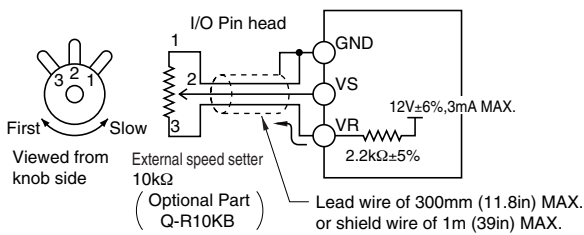
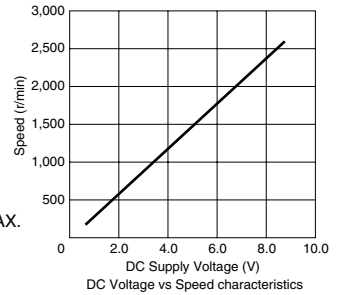
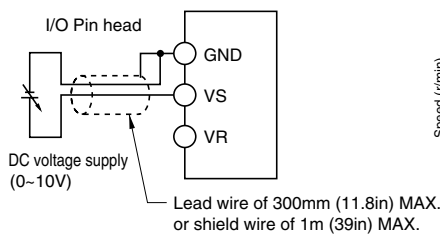

Fig.2 Speed setting by external voltage supply



I/O Pin head Pin No.

	FHD6P20S (PF)-D3 FHD6P40S (PE)-D3	FHD6J60S(PE)-D5
GND	5	10
VS	4	11
VR	3	13

Should be used within specified speed control range, although the speed could be set at out of the speed range.

Item	Setting Method
Speed setting by external speed setter (Optional Part)	Connect as shown in Fig.1 and set by external speed setter. Use variable resistor 10[KΩ] as an external speed setter.
Speed setting by external voltage supply	Connect as shown in Fig.2 and set speed by external voltage supply.

By these function, it is possible to set a speed at outside of Speed control range. But it must be out of our product warranty.

Control sequence

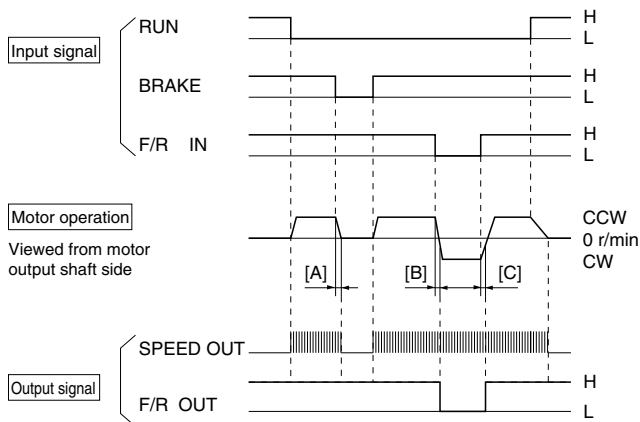

[Notes for BRAKE Operation & Rotation change]

- Do not change (period [A] left) the "F/R IN" signal while the "BRAKE" is activated. "F/R IN" signal should be changed after "BRAKE" is deactivated.
- During the direction of rotation changing (period [B] & [C] left), you need the brake to operate, let it operate only when the both direction of rotation setting signal ("F/R IN") and direction monitor signal ("F/R OUT") is the same.
- When actual motor speed is higher than the setting (by signal input value of "VS"), any switching of the "F/R IN" and "BRAKE" ("H"→"L") must not be made.
- During the brake is operating, set the "RUN" signal at "L" all the time.

WARNING:

In case of different way of use from (1), (2), (3) and (4), (1), (2), and (4) may be the cause of the incorrect operation and (3) may be the cause of the fire or the breakdown.

Electrical shock: By the load condition, the terminal voltage (VM) is raised up to 30 VDC, during switching BRAKE and/or Rotation direction.

(Braking Operation: At higher speed: reverse rotation brake first, then short circuit brake. But at slower speed: short circuit brake only.)

[Notes on "F/R OUT"] (20,40W only)

During the motor is in stop, the "F/R OUT" is held at the same signal as previously outputting. This means ; if the motor stopped once, but the rotation reversed by Cogging torque or by the Load, then the "F/R OUT" is held at reversed signal. Also note that "F/R OUT" signal will delay by 0-5pulses of "SPEED OUT" from the motor rotation switched.

FHD6J60S(PE)-D5

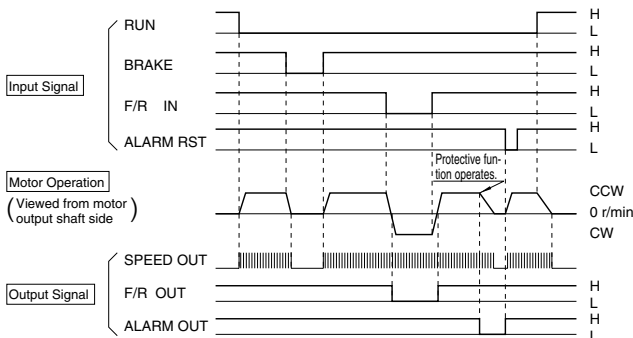

[Notes for "F/R OUT"] (60W only)

In case that motor is not running, "F/R OUT" holds the signal which has been output until motor stops. But according to the condition of use, there may be a case that motor runs reversely by cogging torque, load etc. After it stops. Be careful that in such case "F/R OUT" reverses and holds that condition.

[Notes for "ALARM RST"] (60W only)

Operation should be done by "H". If operated by "L", overload protective function will not work.

Driver outline Unit: mm (inch)
FHD6P20S(PF)-D3
FHD6P40S(PE)-D3

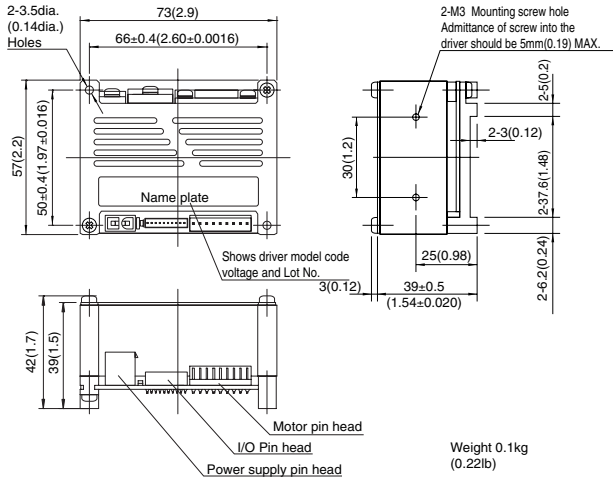

Accessory Unit: mm (inch)

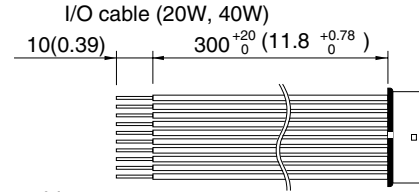

Connection guide

Pin No.	Name	Lead wire color	Lead wire
1	SPEED OUT	Brown	UL3265 AWG28
2	F/R OUT	Red	
3	VR	Orange	
4	VS	Yellow	
5	GND	Green	
6	GND	Blue	
7	ALARM	Purple	
8	F/R IN	Gray	
9	BRAKE	White	
10	RUN	Black	

FHD6J60S(PE)-D5 End of production

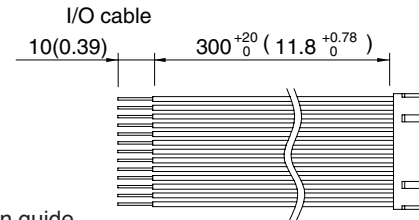
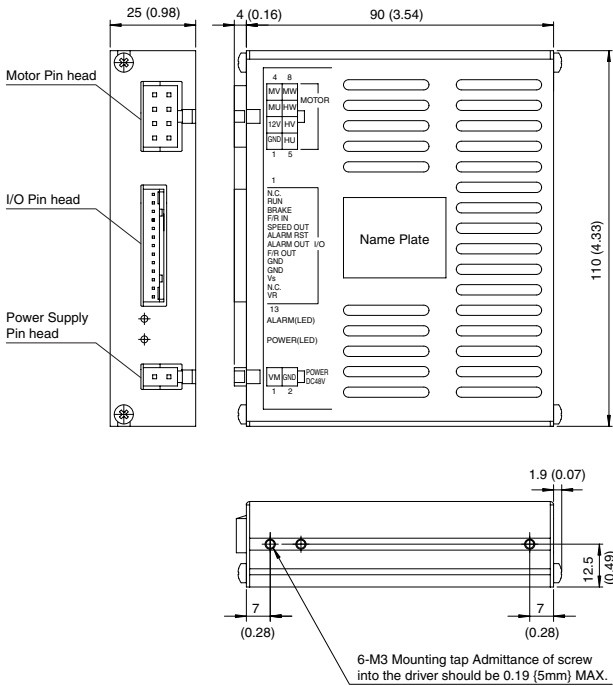

Connection guide

Pin No.	Name	Lead wire color	Lead wire
1	NC	Brown	UL1007 AWG26
2	RUN	Red	
3	BRAKE	Orange	
4	F/R IN	Yellow	
5	SPEED OUT	Green	
6	ALARM RST	Blue	
7	ALARM OUT	Purple	
8	F/R OUT	Gray	
9	GND	White	
10	GND	Black	
11	VS	Brown	
12	NC	Red	
13	VR	Orange	

Power supply cable (20W, 40W, 60W)

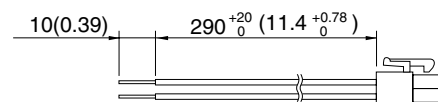

Connection guide

Pin No.	Name	Lead wire color	Lead wire
1	VM	Red	UL1430
2	P. GND	Black	AWG22

Connector model code

Output	Item	Pin head model code on drive	Connector model code on cable		Maker
			Housing	Contact (chained)	
20W 40W	I/O connection	B10B-ZR(LF)(SN)	ZHR-10	SZH-002T-P0.5	JST
	Power supply connection	5566-02A	5557-02R	5556T	MOLEX
	Motor connection	IL-G-9P-S3T2-SA	IL-G-9S-S3C2-SA	IL-G-C2-SC10000	JAE
60W	I/O connection	IL-G-13P-S3L2-SA	IL-G-13S-S3C2-SA	IL-G-C2-SC-10000	JAE
	Power supply connection	5569-02A1	5557-02R	5556T	MOLEX
	Motor connection	5569-08A1	5557-08R	5556T	MOLEX

■Protection

Protection function	Protection		Alarm Release
	Setting	Operation	
Overload Protection	When the load exceeds the rated torque for more than 5 seconds, the driver will cause the motor to stop and "ALARM" will output "L".	Motor is stepped and "ALARM" outputs "L"	Cool down the driver fully, and input "L" into "ALARM RST" until "ALARM OUT" changes to "H". Or disconnect power supply for more than 1 minute.

Do not use this function to determine whether or not the load exceeds the rated torque. Please make sure to check the load is lower than the rated torque before use.

■Motor/Driver/Cable/ model code table Unit: mm (inch)

		Motor driver set model code	Motor model code	Driver model code	Power supply cable model code	I/O Cable model code
FHD series	Palm mini PLUS / J-Book driver	FHD6P20S-D3	FH6S20-D3	FHD620PD3	FED-CNSL03 300 (11.8)	FED-CNPL03 300 (11.8)
		FHD6P20PF-D3	FH6PF20N-D3	FHD620PD3	FED-CNSL03 300 (11.8)	FED-CNPL03 300 (11.8)
		FHD6P40S-D3	FH6S40-D3	FHD640PD3	FED-CNSL03 300 (11.8)	FED-CNPL03 300 (11.8)
		FHD6P40PE-D3	FH6PE40N-D3	FHD640PD3	FED-CNSL03 300 (11.8)	FED-CNPL03 300 (11.8)
		FHD6J60S-D5	FH6S60J-D5	FHD660JD5	FED-CNSL03 300 (11.8)	FED-CNIL03 300 (11.8)
		FHD6J60PE-D5	FH6PE60J-D5	FHD660JD5	FED-CNSL03 300 (11.8)	FED-CNIL03 300 (11.8)

NOTE) Cable types for FHD series are the same as FED series, because they are used in commonly.

High power simple type

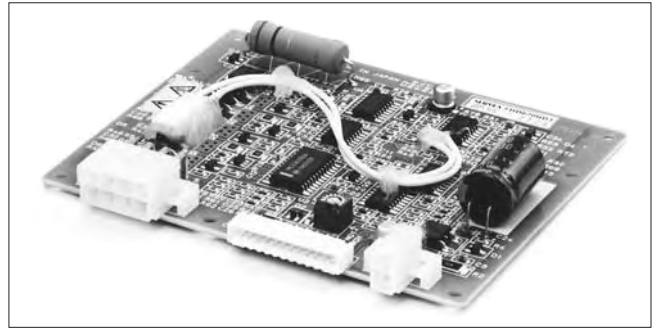

■Specification

Model on motor	Plain shaft type		FH6S20H-D3		FH6S40H-D3	
	Pinion shaft type		FH6PF20H-D3		FH6PE40H-D3	
Model on driver			FHD620HD3		FHD640HD3	
Rated voltage	V (DC)		24		24	
Rated output	W		20		40	
Speed control range	r/min		200~2500		200~2500	
Rated torque	mN · m		98		200	
	oz · in		14		28	
MAX. instantaneous torque (in 5sec.)	mN · m		150 (2000r/min MAX.)		290 (500r/min MAX.)	
	oz · in		21 (2000r/min MAX.)		42 (500r/min MAX.)	
Rated speed	r/min		2000		2000	
Speed setting method			① Speed setting by external speed setter (Sold separately: model code Q-R10KB)			
			② Speed setting by external voltage supply 0~10V			
Speed setting	(r/min)/V		300±5%			
Speed variation			Against load	±1%	0~rated torque at rated voltage and speed	
			Against voltage	±1%	Rated voltage ±10% at rated speed, no load	
			Against temperature	±3%	20±20°C at rated voltage and speed, no load	
Input and output signal		Input	RUN, BRAKE, F/R IN, ALARM RST H: Open collector L: GND (0~0.8V)			
		Output	ALARM, HU OUT, HV OUT Open collector output DC30V MAX. 10mA MAX.			
Speed pulse	Pulse/Revolution		7		7	
Current	Rated (Ave.)		1.8 MAX.		3.1 MAX.	
	MAX. (Peak)		7 MAX.		10 MAX.	
Protection functions			Over load protection When an exceeding torque than rated is applied to motor for more than about 5 sec., Stop motor and outputs "L" from "ALARM" (20W, 40W) "ALARM OUT". To release alarm: Input "L" in the ALARM RST or Turn off the power supply more than 1 min. period.			
Others			Operation temperature: 0~40°C (no condensation) continuous duty. The motor flange surface temp. must be 80°C MAX. (Ambient temperature 40°C without heat sink) Motor dielectric strength: Withstand for 1min. under AC500V 50Hz (Between case and coil) Motor insulation resistance: 10MΩMIN. (20W, 40W) (Between case and coil by DC500V tester)			
Gear ratio	Speed (r/min)		Applicable MAX. Torque for gearheads			
	at 200r/min	at 2000r/min	6H□EBN		8F□EBN	
			mN · m	oz · in	mN · m	oz · in
5	40	400	390	56	780	110
10	20	200	780	110	1600	220
25 (25.44)	8	80	1700	240	3600	510
50 (49.6)	4	40	3500	500	7000	990

- Although the rotation speed range in the high-speed area expands more than that shown in the above table, the allowable torque may decrease. Refer to the torque rotation speed graph.
- □: rotation of gear head output shaft becomes reverse direction of motors.
- In case of 8F□EBN value in () should be used as gear ratio.

Torque Speed/Current (TYP.) Characteristics FH6S(PF)20H-D3+FHD620HD3

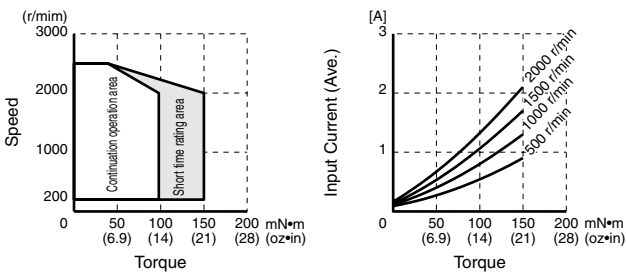

FH6S(PE)40H-D3+FHD640HD3

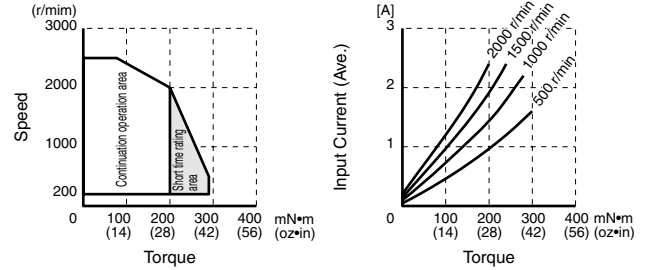

Input & output terminals and wiring diagram

Item	Pin No.	Read Wire Color	Symbol	Input or Output	Function	Standard · Condition
Power supply	1	Red	VM	Input	Power supply positive for driver	DC24 V ±10%
	2	Black	P.GND	—	Power supply GND for driver	
I/O	1	Brown	HU OUT	Output	7 Pulse/Revolution ※1	H: Open collector DC30V MAX. L: 0~0.8 V, 10 mA MAX.
	2	Red	HV OUT	Output		
	3	Orange	ALARM OUT	Output	H: Normal operation L: Alarm output	
	4	Yellow	VR	Output	Power supply positive for external speed setter	
	5	Green	VS	Input	Speed setting signal positive	0~10 V
	6	Blue	GND	—	Speed setting signal GND	
	7	Purple	GND	—	GND for I/O Signal	
	8	Gray	F/R IN	Input	H: CCW L: CW (Viewed from motor output shaft side)	H: Open collector L: 0~0.8 V
	9	White	BRAKE ※2	Input	H: BRAKE Deactivated L: BRAKE activated	
	10	Black	RUN	Input	H: Stop L: Start	
11	Brown	ALARM RST ※3	Input	H: Normal operation L: Reset		
	12	Red	N.C.	—	Not used	Must be operated in the open state.

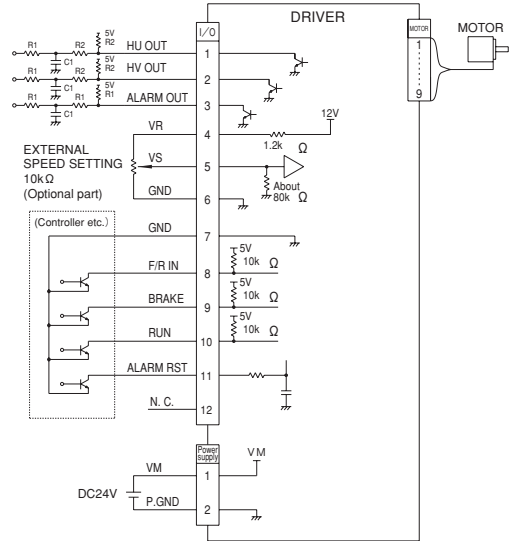

Part name	Recommended value
R1	4.7KΩ
R2	1KΩ
C1	0.01μF

*1 "HU OUT" signal and "HV OUT" signal are shown below.

Motor rotation (viewed from motor output shaft side)

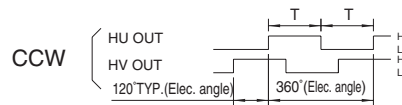
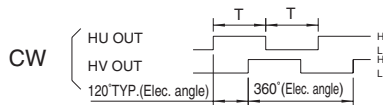

T: Time (vary by its speed)

- ※ 2 • Brake specification: Short brake between terminals
- "BRAKE" has priority over "RUN".
- During rotation direction switching operation, "BRAKE" terminal voltage may reduce due to internal processing.

- ※ 3 In case of "L", the overload protection function is canceled. If overload operation is performed in this state, the motor may burn out.

Protection

Protection function	Protection		Alarm Release
	Setting	Operation	
Overload Protection	When the load exceeds the rated torque for more than 5 seconds, the driver will cause the motor to stop and "ALARM" will output "L".	Motor is stepped and "ALARM" outputs "L"	Cool down the driver fully, and input "L" into "ALARM RST" until "ALARM OUT" changes to "H". Or disconnect power supply for more than 1 minute.

Do not use this function to determine whether or not the load exceeds the rated torque. Please make sure to check the load is lower than the rated torque before use. When the overload protection function is canceled ("ALARM RST" is in the "L" state) and temperature rises rapidly due to motor restraint, the motor may burn out. Make sure to set "ALARM RST" to "H" before operating the motor.

Control sequence

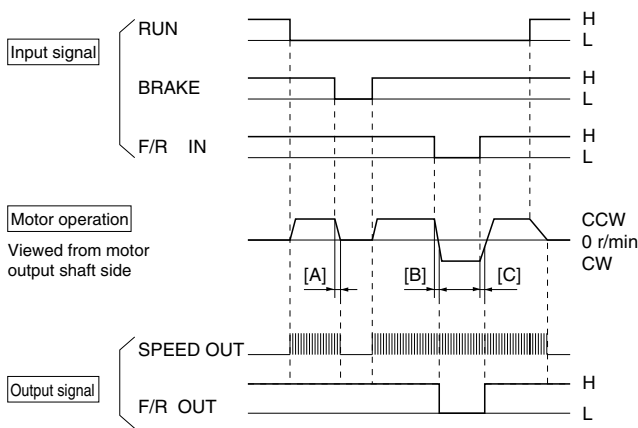

[Notes for BRAKE Operation & Rotation change]

- Do not change (period [A] left) the "F/R IN" signal while the "BRAKE" is activated. "F/R IN" signal should be changed after "BRAKE" is deactivated.
- During the direction of rotation changing (period [B] & [C] left), you need the brake to operate, let it operate only when the both direction of rotation setting signal ("F/R IN") and direction monitor signal ("F/R OUT") is the same.
- When actual motor speed is higher than the setting (by signal input value of "VS"), any switching of the "F/R IN" and "BRAKE" ("H→L") must not be made.
- During the brake is operating, set the "RUN" signal at "L" all the time.

WARNING:

In case of different way of use from (1), (2), (3) and (4), (1), (2), and (4) may be the cause of the incorrect operation and (3) may be the cause of the fire or the breakdown.

Electrical shock: By the load condition, the terminal voltage (VM) is raised up to 30 VDC, during switching BRAKE and/or Rotation direction.

(Braking Operation: At higher speed: reverse rotation brake first, then short circuit brake. But at slower speed: short circuit brake only.)

[Notes on "F/R OUT"] (20,40W only)

During the motor is in stop, the "F/R OUT" is held at the same signal as previously outputting. This means ; if the motor stopped once, but the rotation reversed by Cogging torque or by the Load, then the "F/R OUT" is held at reversed signal. Also note that "F/R OUT" signal will delay by 0~5pulses of "SPEED OUT" from the motor rotation switched.

Speed setting

Fig.1 Speed setting by external speed setter

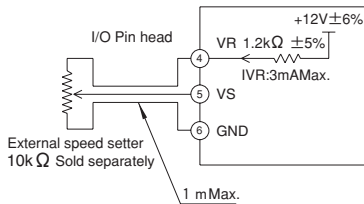
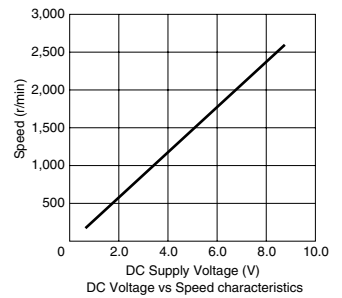
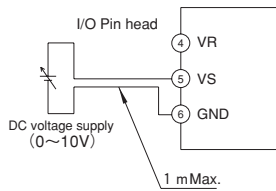

Fig.2 Speed setting by external voltage supply



Item	Setting Method
Speed setting by external speed setter (Optional Part)	Connect as shown in Fig.1 and set by external speed setter. Use variable resistor 10[KΩ] as an external speed setter.
Speed setting by external voltage supply	Connect as shown in Fig.2 and set speed by external voltage supply.

By this function, it is possible to set a speed at outside of Speed control range. But it must be out of our product warranty.

Driver outline Unit: mm (inch)

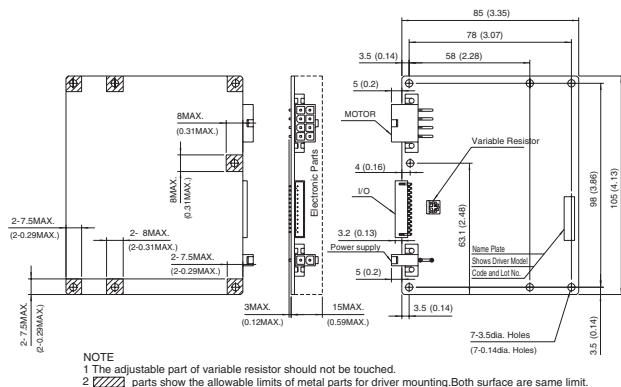

Accessory Unit: mm (inch)

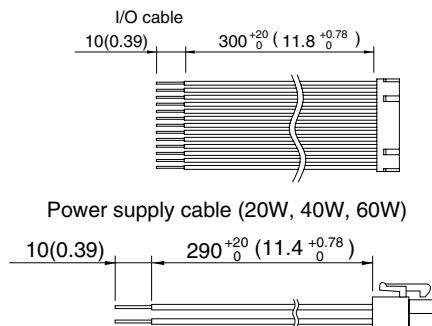

Connector model code

Item	Pin head model code on drive	Connector model code on cable		Maker
		Housing	Contact (chained)	
I/O connection	53325-1210	51090-1200	50212-8000	MOLEX
Power supply connection	5566-02A	5557-02R	5556T	
Motor connection	5569-08A1	5557-08R	5556T	

BONDY

INDUSTRIAL EQUIPMENT SUPPLIER



Transmission



Handling



Motor & Gear



Vacuum Conveying

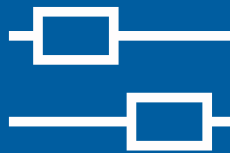

Linear



Support

See our products and solutions at

www.bondy.dk

For ordering and questions call (+45) 70 15 14 14