

# Piab MX suction cup

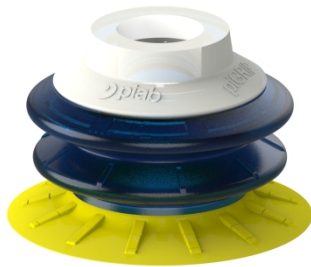

- For logistics, warehousing, e-commerce and recycling applications.
- Outstanding for picking different objects.
- A multi-purpose suction cup with extreme gripping capabilities on any surface.
- Very good for handling difficult bags, pouches, cardboard boxes and recycled objects.
- The cup is made of Duraflex®, a material that features the elasticity of rubber and wear resistance of polyurethane.
- The material has a fantastic elastic memory and “mark free” capabilities.
- Trippel durometer cup design: Thin soft lip, sturdy bellow and firm neck – gives outstanding sealing capabilities and great holding force in dynamic grips.
- A wide range of fitting options (uses piGRIP® fittings).
- Exceptional sealing capabilities at lower vacuum levels - forgiving for handling different types of objects, less vacuum flow needed.
- Energy saving - less need of high vacuum flows give significant reduction of compressed air usage.

## Lifting force

Description	Vertical			Parallel		
	20 -kPa	40 -kPa	60 -kPa	20 -kPa	40 -kPa	60 -kPa
Lifting forces	12.6 N	18.4 N	23.0 N	8.8 N	12.9 N	16.1 N

## Technical data

Description	Unit	Value
Internal volume	cm <sup>3</sup>	8.0
Weight	g	8
Min. curve radius -60 kPa	mm	18.0
Max. vertical movement	mm	10.1
Application	-	Bag handling, Bag opening/thin paper - slip sheets/film
Material	-	Polyurethane, PUR
Colour	-	Yellow / Transparent blue
Suction cup model	-	MX
Suction cup shape	-	Multibellows
Hardness °Shore A	-	30 and 60 °Shore A
Temperature range (°C)	°C	10-50
Actuated outer diameter, max	mm	40.5

## Material resistance, Polyurethane, PUR

Description	Value
Alcohol	Fair
Concentrated acids	Fair
Ethanol	Fair
Hydrolysis	Fair
Methanol	Poor
Oil	Excellent
Oxidation	Poor
Petrol	Fair
Wear resistance	Excellent
Weather & ozone	Excellent

## Dimensional drawing

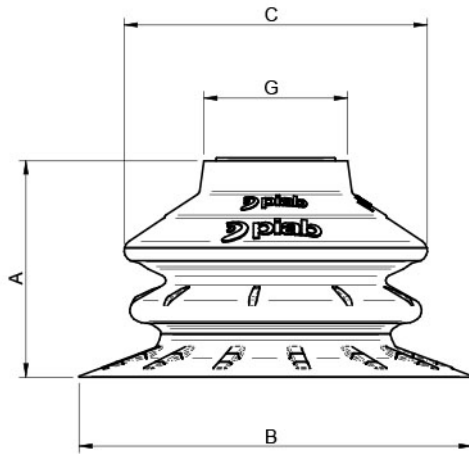

Product code	Description	Unit	Value
A	Building height	mm [inch]	27.0 [1.06"]
B	Diameter (lip)	mm [inch]	42.0 [1.65"]
C	Diameter (bellows)	mm [inch]	36.8 [1.45"]
G	Diameter (upper)	mm [inch]	19.0 [0.75"]

## Ordering information – Current configuration

Description MX suction cup	Product code S.MX42P3060.XXX.00
Suction cup size	Ø 42mm
Suction cup material	Polyurethane, PUR
Hardness	30 and 60 °Shore A
Fitting type	None
Fitting size	None
Fitting style	None
Options	None

## Ordering information, spare parts

Description	Art. No.
Suction Cup MX42P	0231424



Internal volume

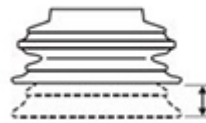

Max. vertical movement

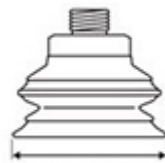

Diameter (lip)



Min. curve radius -60 kPa

### Values specified in this data sheet are tested at (unless otherwise stated):

- Room temperature (20°C [68°F] ± 3°C [5.5°F]).
- Standard atmosphere (101.3 [29.9 inHg] ± 1.0 kPa [0.3 inHg]).
- Relative humidity 20-70%.
- Compressed air quality, DIN ISO 8573-1 class 4.

Storage guidelines (scan QR code)



Mounting instruction MX-cups (scan QR code)

