

AGC Linear Slide Bushing

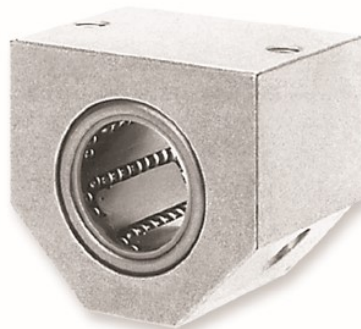
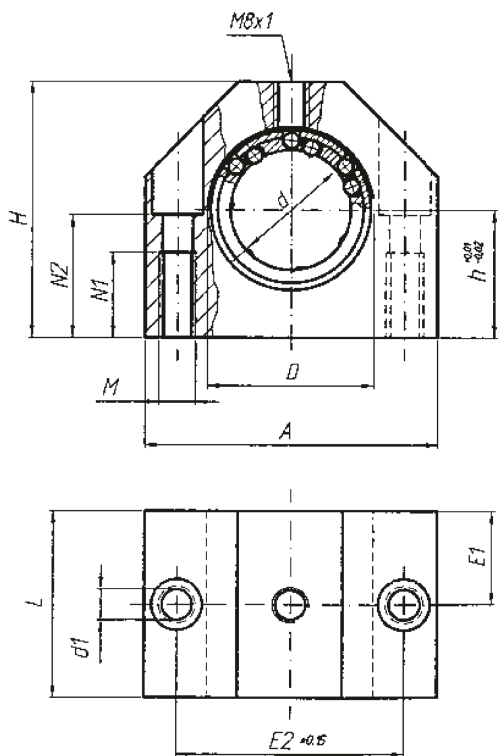

single closed
compact version
lubrication hole M8 x 1

Linear Bearing Housings

Dimensions in mm

Part-No.	Ø d	Ø D	A	H	h	L	E1	E2	Ø d1	N1	N2	M	weight (kg)
AGC-08	8	15	32	27	14	24	12	23	3,4	9	13	M4	0,04
AGC-10	10	17	40	33	16	26	13	29	4,3	11	16	M5	0,10
AGC-12	12	19	40	33	17	28	14	29	4,3	11	16	M5	0,18
AGC-16	16	24	45	38	19	30	15	34	4,3	11	18	M5	0,27
AGC-20	20	28	53	45	23	30	15	40	5,3	13	22	M6	0,32
AGC-25	25	35	62	54	27	40	20	48	6,6	18	26	M8	0,66
AGC-30	30	40	67	60	30	50	25	53	6,6	18	29	M8	0,95
AGC-40	40	52	87	76	39	60	30	69	8,4	22	38	M10	1,82
AGC-50	50	62	103	92	47	70	35	82	10,5	26	46	M12	2,52

- Load ratings according to the specification of the bearing
- fixing screws DIN 912-8.8, circlip DIN 7980
- weight value considering the ball bushing

Ordering code

AGC-	Ø-	C
linear housing, closed, compact	shaft diameter	C linear ball bushing (refer to page 19) FMT linear slide bushing (refer to page 26)