



Item no: 0206915

Suction cup BFF30P Polyurethane 55/60, 3/8" NPT female

The BFF-P design is suitable for oily surfaces, uneven/curved surfaces or if level compensation is needed, for example in de-stacking applications. The flat inner support gives stability during movement in any orientation. Special designed friction cups for oily surfaces, such as sheets in metal forming processes... Thanks to the strong grip on oily surfaces, the suction cups can withstand high shear forces, typically 2–4 times more than corresponding conventional suction cups.

- Special designed friction cups for oily surfaces, such as sheets in metal forming processes.
- Normal wear on friction cup will not affect the long term shear force performance.
- Best choice if $> 0.1\text{g/m}^2$ press oil is used on the sheet.
- Thanks to the strong grip on oily surfaces, the suction cups can withstand high shear forces, typically 2–4 times more than corresponding conventional suction cups.
- The "BFF" design is suitable for uneven/curved surfaces or if level compensation is needed, for example in de-stacking applications.
- The flat inner support gives stability during movement in any orientation.
- DURAFLEX® suction cups manufactured in a specially developed material that features the elasticity of rubber and wear resistance of polyurethane. The material does not leave any marks on the objects handled.

General

Application	Oily sheet metal
Suction cup shape	Bellows
Material	PU55, PU60
Suction cup model	BFF
Weight	38.3 g
Volume	5 cm ³
Suction cup model	BFF30P Dry metal sheet
Specification	Dry metal sheet
Movement, vertical max.	5.25 mm
Curve radius, min.	15 mm
Suction cup model	BFF30P Oily steel plate
Specification	Oily steel plate





Fitting

Fitting size	3/8"
Fitting style	Female
Fitting type	NPT-thread

Dimension

Height	28.6 mm
Outer diameter, actuated	30.4 mm
Outer diameter	30 mm

Performance - lifting forces

		
BFF30P Dry metal sheet		
60 -kPa	24 N	11 N
90 -kPa	27 N	13.5 N
		
BFF30P Oily steel plate		
60 -kPa	23 N	5.5 N
90 -kPa	30 N	7.8 N

Material

Name	PU55	PU60
Colour	Orange	GreenTransparent
Temperature	10 - 50 °C	10 - 50 °C
Hardness	55 °Shore A	60 °Shore A

	PU55	PU60
Alcohol	n/a	n/a
Concentrated acids	+	+
Ethanol	+	+
Hydrolysis	+	+
Methanol	-	-
Oil	+++	+++
Oxidation	-	-
Petrol	+	+
Wear resistance	+++	+++
Weather and ozone	+++	+++

Dimensional drawings 

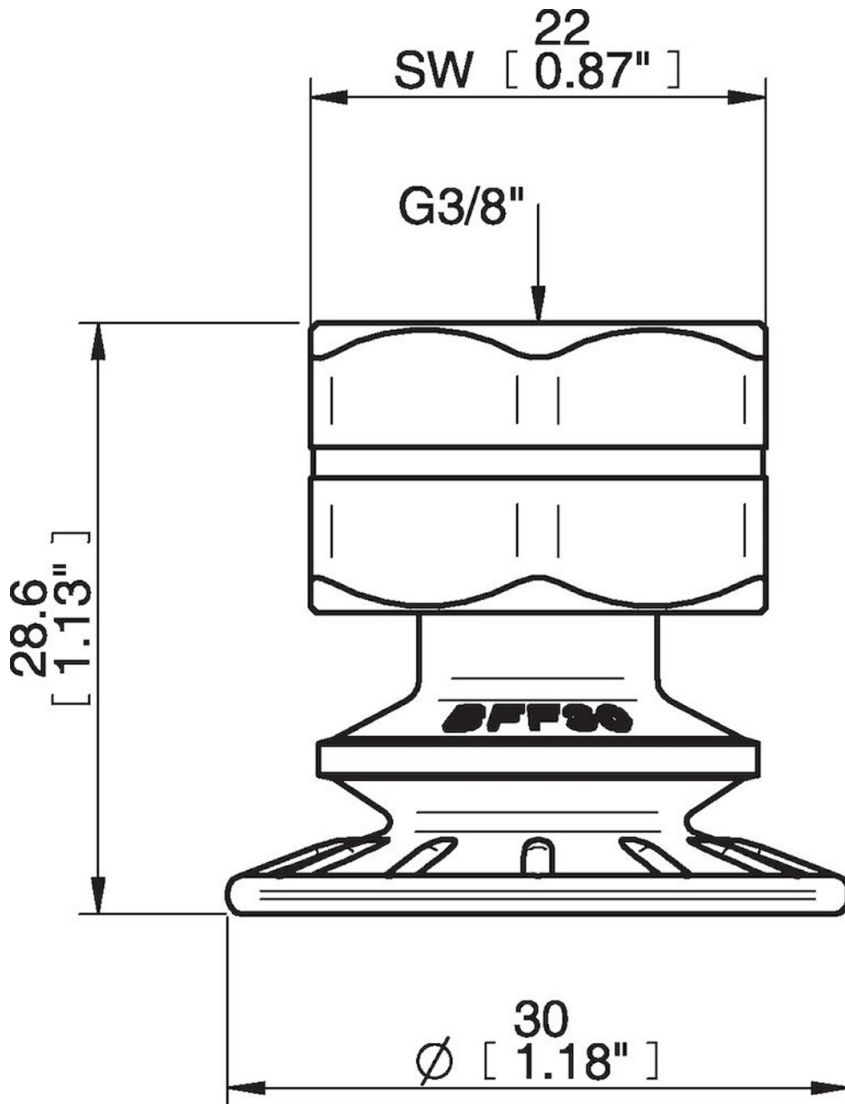

Values specified in the data sheet are tested at:

- Room temperature: $(20^{\circ}\text{C}\ [68^{\circ}\text{F}]\ \pm\ 3^{\circ}\text{C}\ [5.5^{\circ}\text{F}])$
- Standard atmosphere: $(101.3\ [29.9\ \text{inHg}]\ \pm\ 1.0\ \text{kPa}\ [0.3\ \text{inHg}])$
- Relative humidity: 0-100%
- Compressed air quality: DIN ISO 8573-1 class 4