

# XLF150 Extra Large Flat cup, G1/2" female, 0127131

- Suitable for handling large and heavy sheets, such as glass and metal, with a flat or slightly concave surface.
- Friction pattern increases safety and capability to handle tilted or standing glass/metal sheets.
- Double lip design increases safety against over-load or tear on the outer lip.
- Durable and abrasive resistant material reduces the risk for marks.
- Flat mounting plate facilitates customized mounting interfaces.
- Auxiliary port, suitable for vacuum sensing or efficient blow-off/release.



## General

Specification	Outer lip
Curve radius	500 mm
Movement, vertical max.	8 mm
Application	Glass handling, Mark Free, Dry sheet metal
Material	Nitrile-PVC (NPV)
Suction cup model	XLF
Suction cup shape	Flat
Volume	145 cm <sup>3</sup>
Weight	362 g

## Fitting

Fitting size	1/2"
Fitting style	Female
Fitting type	G-thread
Fitting option	None

## Dimension

Height	27 mm
Outer diameter	153 mm
Outer diameter, actuated	157.7 mm

## Performance — lifting forces, Outer lip

		
20 -kPa	520 N	281 N
60 -kPa	770 N	425 N
90 -kPa	1130 N	663 N

## Performance — lifting forces, Inner lip

		
20 -kPa	330 N	281 N
60 -kPa	500 N	425 N
90 -kPa	780 N	663 N

## Material

	Nitrile-PVC (NPV)
Colour	Black
Hardness	50 °Shore A
Temperature	0 – 90 °C

## Material resistance

	Nitrile-PVC (NPV)
Alcohol	++
Concentrated acids	+
Ethanol	N/A
Hydrolysis	++
Methanol	N/A
Oil	+++
Oxidation	++
Petrol	+++
Wear resistance	+++
Weather and ozone	++

Dimensional drawings

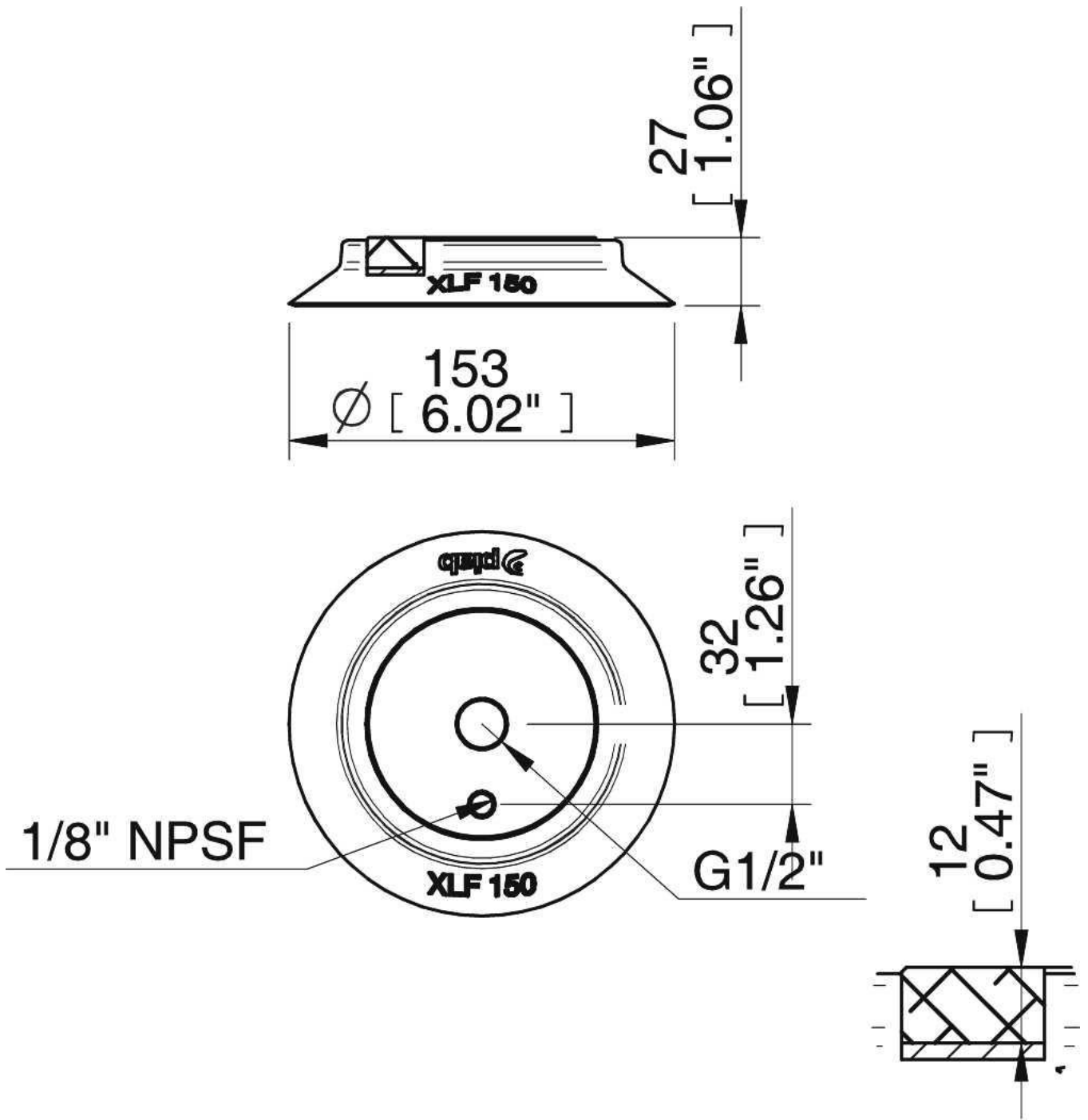

Values specified in the data sheet are tested at:

Room temperature	(20°C [68°F] ± 3°C [5.5°F])
Standard atmosphere	(101.3 [29.9 inHg] ± 1.0 kPa [0.3 inHg])
Relative humidity	0-100%
Compressed air quality	DIN ISO 8573-1 class 4