



Item no: 0106355

### Suction cup F110P Polyurethane 30/60, G1/2" female, with mesh filter

Suitable for flat and rough surfaces. The cleats stop deformation by preventing suction of the object into the cup. The suction cup has good stability and very little movement. Also suitable when the lifting force is parallel to the surface as the cleats increase friction. DURAFLEX® are suction cups manufactured in a... specially developed material that features the elasticity of rubber and wear resistance of polyurethane. The material is mark-free.

- Suitable for flat and rough surfaces.
- Fair stability and little inherent movement.
- Recommended when the lifting force is parallel to the surface of the object.
- In the two-coloured suction cup the bellows and the sealing lip are of different hardnesses, which makes the suction cup strong and stable and, at the same time, soft and flexible.
- DURAFLEX® suction cups manufactured in a specially developed material that features the elasticity of rubber and wear resistance of polyurethane. The material does not leave any marks on the objects handled.

#### General

Application	MarkFree, DrySheetMetal
Suction cup shape	Flat
Material	PU30, PU60
Suction cup model	F
Weight	82 g
Volume	60 cm <sup>3</sup>
Suction cup model	F110P PU30 PU60
Movement, vertical max.	4 mm
Curve radius, min.	250 mm

Fitting

Fitting option	Filter mesh
Fitting size	1/2"
Fitting style	Female
Fitting type	G-thread

Dimension

Height	36 mm
Outer diameter, actuated	119.6 mm
Outer diameter	115 mm

Performance - lifting forces

	F110P	PU30	PU60
20 -kPa		↑ 167 N	→ 149 N
60 -kPa		↑ 432 N	→ 441 N
90 -kPa		↑ 591 N	→ 617 N

Material

Name	PU30	PU60
Colour	Yellow	GreenTransparent
Temperature	10 - 50 °C	10 - 50 °C
Hardness	30 °Shore A	60 °Shore A

	PU30	PU60
Alcohol	n/a	n/a
Concentrated acids	+	+
Ethanol	+	+
Hydrolysis	+	+
Methanol	-	-
Oil	+++	+++
Oxidation	-	-
Petrol	+	+
Wear resistance	+++	+++
Weather and ozone	+++	+++

Dimensional drawings 

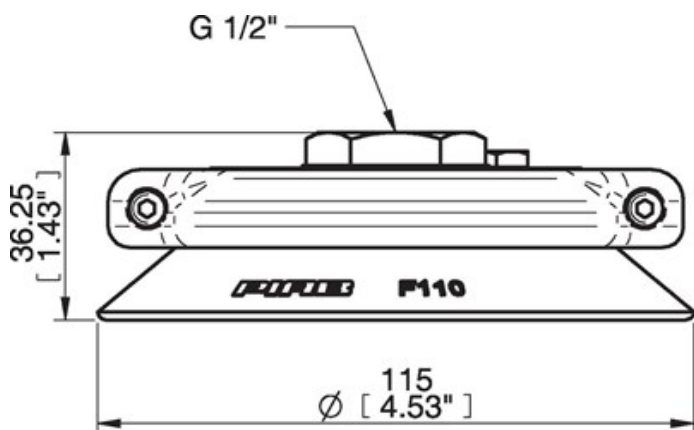

Values specified in the data sheet are tested at:

- Room temperature: (20° C [68° F] ± 3° C [5.5° F])
  - Standard atmosphere: (101.3 [29.9 inHg] ± 1.0 kPa [0.3 inHg])
  - Relative humidity: 0-100%
  - Compressed air quality: DIN ISO 8573-1 class 4
- 

#### Accessories

- 0111593 | Suction cup F110P Polyurethane 60
- 0106796 | Suction cup F110P Polyurethane 30/60, for thread insert
- 0107322 | Suction cup F110P Polyurethane 60, for thread insert
- 0100557 | Fitting 110 G3/8" female, with mesh filter
- 0100559 | Fitting 110, 3/8" NPSF female, with mesh filter
- 0100563 | Fitting 110, G1/2" female, with cone valve
- 0107148 | Thread insert G3/8" male, with O-ring and mesh filter

#### Spare parts

- 0104725 | Suction cup F110P Polyurethane 30/60
- 0100561 | Fitting 110, G1/2" female, with mesh filter